

IQ4

HEALTHCARE

The KEN IQ4 belongs to the new generation of washer-disinfectors made by KEN HYGIENE SYSTEMS.

The IQ4 is specially designed for use in smaller wash-rooms in hospitals to wash scissors, instruments and wash bowls among other things.

The IQ4 has a small footprint, and is characterised as a smaller instrument washer with a fast process time and great flexibility.

The machine guarantees the execution of optimal, reliable and safe processes at the lowest costs.



Our KEN IQ4 model combines innovation, technology and ergonomics with the reliability, functionality and performance characteristics of KEN equipment, being able to wash and disinfect surgical instruments in up to 4 levels with a capacity of up to 8 DIN 1/1 baskets.

The machine is available with a manual drop down version with one or two doors. The double door models ensure an effective barrier between the unclean side and the clean side, optimizing the required level of hygiene and reducing the risk of hospital infections as well as keeping a safe working environment for the staff.

This equipment has been manufactured in accordance with European Union Directives and has consequently been constructed based on EN ISO 15883-1, 2, 5, 6 standard. This include among others capacity test and cleaning efficacy test.

Main advantages

- Compact unit with external dimensions H: 1790 x W: 600 x D: 700 mm
- High capacity for cleaning, disinfection and drying of serveral equipments
- High reprocessing capacity
- Washing chamber manufactured in AISI 316L quality stainless steel
- The IQ4 units include double LED lighting inside the chamber
- The external paneling of the machine is made of AISI 304 quality stainless steel
- The control panel is made in elegant black polycarbonate for protection of the integrated OLED display
- Upper access door to the control and maintenance unit is made in elegant white tempered glass integrated in a AISI 304 stainless steel frame.
- Available with manual hinged fold down doors manufactured in double tempered glass with HST treatment (Heat-Soak-Test).
- The pass-through versions incorporate a door locking system that prevents simultaneous opening of both doors.
- Ergonomic loading height of 750 mm for easy and safe handling, even with the heaviest loads.
- Remote service access
- Low noise level <53 dB
- Full process validation

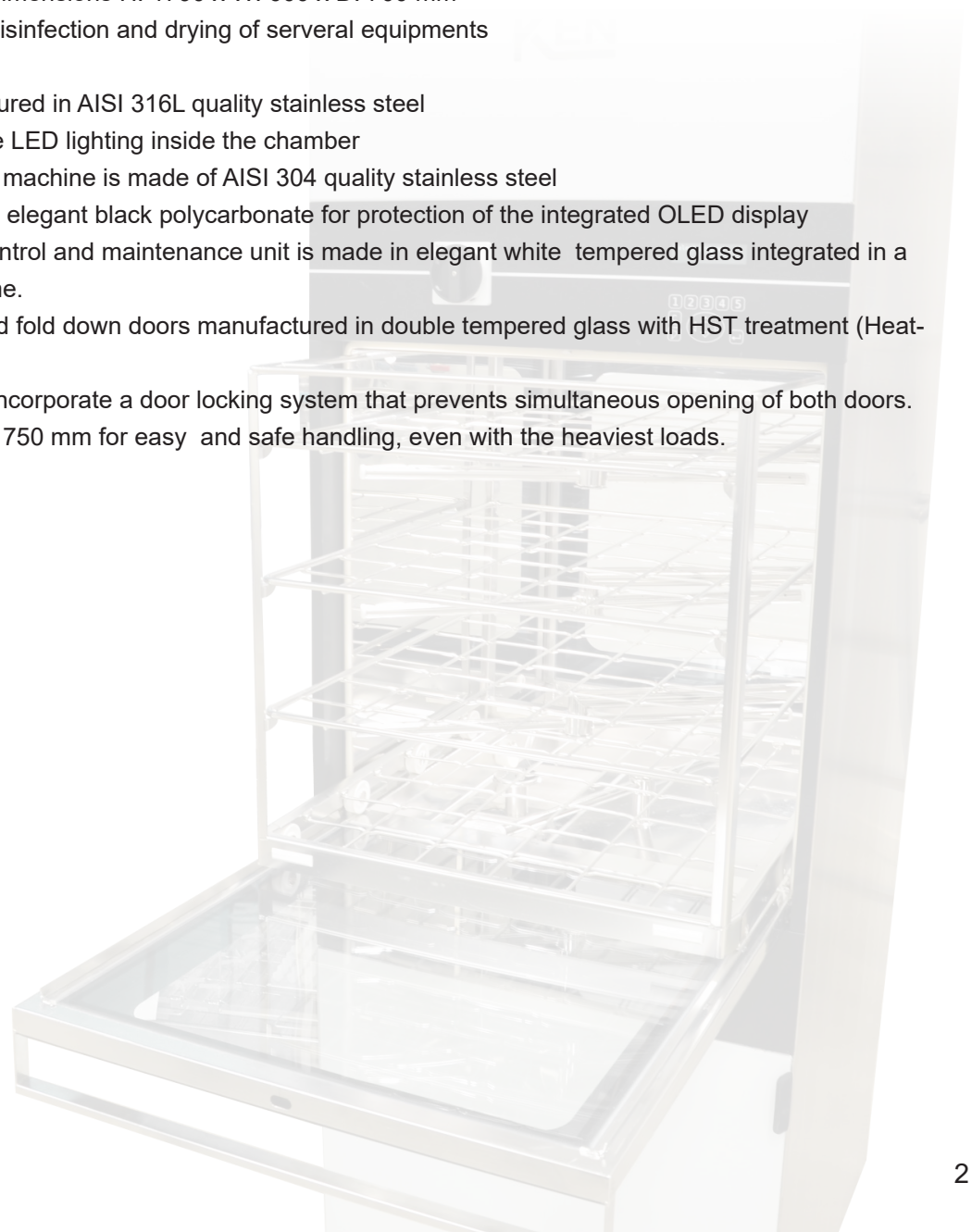

Sustainable goals



KEN HYGIENE SYSTEM take the UN sustainable development goals seriously.

The IQ series has the lowest consumption of water, energy and chemicals available on the market. Further the IQ series adapts the water intake to the rack loaded into the unit. This step taken not only contributes to a better environment but also benefit the healthcare facility to lower the costs on energy and water and on chemical consumables but also reduces the total cost of ownership. For the staff using the units the added benefits results in faster and more reliable processes thus increasing the washing capacity and daily through-put.

We also take the working environment seriously. We design our IQ units to be as ergonomic as possible and our loading racks to be as user friendly as possible. Also noise is a high stress factor. We have achieved a noise level as low as 56.6 dB(A) when washing and 52.6 dB(A) when drying. This is unique.

Optional fitting of an integrated thermal printer and/or external documentation systems for complete documentation of processes.

Thanks to the XMLconnect the KEN IQ4 washer is able to connect to any external traceability software.

Documentation

A machine delivery includes one set of the following documentation:

- User manual
- Service manual
- Installation manual
- Standard spare parts list
- Quality inspection certificate
- Temperature test diagram
- Declaration of conformity



Standards

KEN HYGIENE SYSTEMS IQ5 complies with the following standards:

- EN ISO 15883-1-2-5-6: Washer disinfectant
- EN ISO 13485:2016 + AC: 2016: Medical devices - Quality management system
- EN 1717:2002: Protection against pollution of potable water
- EN 61010-2-040: 2015: Safety requirements for electrical equipment for measurement, control, and laboratory use - Part 2-040: Particular requirements for sterilizers and washerdisinfectors used to treat medical materials.
- EN 60601-1-2:2015: Electromagnetic disturbances - Requirements and tests

Made according to Annex IX of the European Medical Device Directive 93/42/EEC and manufactured in accordance with Annex I to that directive.

The KEN IQ4 washing unit has multiple options available to the user in order to adapt its functionality to the requirements of the facilities:



Control units

Intuitive and user friendly thanks to our KEN Com 2015 user interface, common for all KEN machines. The KEN IQ washer disinfector performs a comprehensive control of all parameters and processes performed. Its dual independent microprosor ensures the cleaning, disinfection and drying of materials cycle after cycle.

The microprocessor has a storage capacity for up to 40 different programs that have an open and unlimited configuration structure and allows a high level of personalized cycles in order to meet the needs that a healthcare facility may require.

The KEN IQ family can all be network connected through the integrated Ethernet socket. This allows for direct communication with the unit through any web browser without the use of any specific software. Connecting to the batch datas of the unit allows the user to print out or digitally store individual program reports.

These standard options can save the use of a printer and the use of paper. Connecting the unit to the network also allows if access is granted KEN service specialists to connect to the machine and assist in case of breakdown or to offer remote assistance to users. You will find the emergency pushbutton on both sides of the unit. General switch on load side of washer.

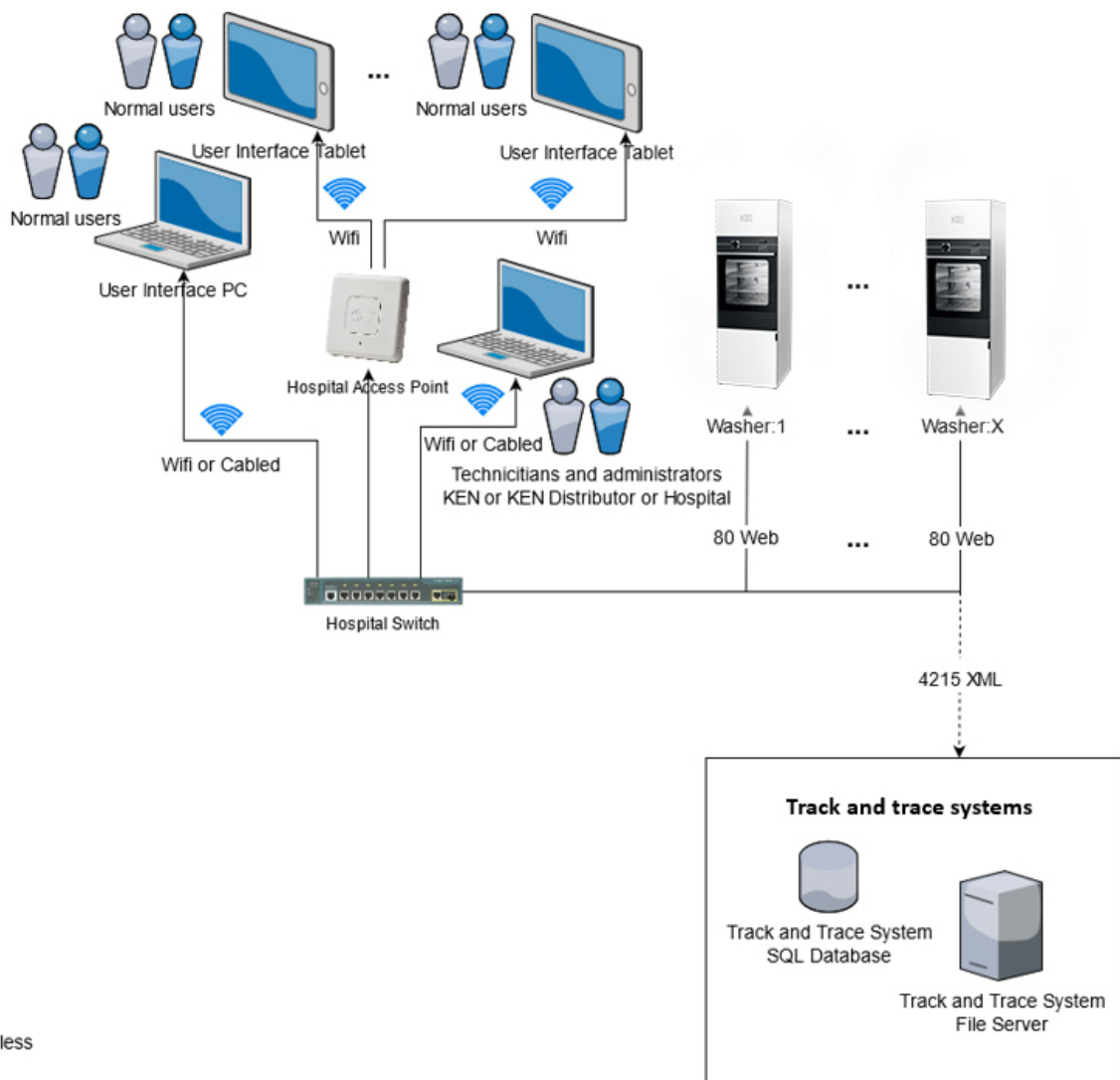

Rev 1.0a
All communication is over TCP unless otherwise indicated.

Technical specification	IQ4
Outer dimensions	H: 1790 x W: 600 x D: 700 mm
Operative chamber dimensions	H: 550 x W: 540 x D: 610 mm
Weight excl. packaging	165 kg
Weight incl. packaging	180 kg
Operative volume, wash chamber	181 L
Total volume, wash chamber	226 L
Capacity, baskets	4 x 2 DIN-baskets 480x250x50
Cycle time, standard	50-60 min
Exhaust connections	ø60 1,4 m ³ /min.
Water connections	2 x 3/4 (3rd is optional)
Cold water	200-800kPa, ≥ 15 L/min, 5-30°, 0-30° dH
Hot water	200-800kPa, ≥ 15 L/min, 30-70°, 0-3° dH
Deminerlized / RO water	200-800kPa, ≥ 15 L/min, 5-70°C, conductivity 3-200 µS
Washing / Drying	<56.6 dB (A) / <52.6 dB (A)
Water consumption per phase	Approx. 12-15 L
Power supply options	3x200-440V AC + N + PE, 50/60 Hz 10-13 kW
Programs available	10 standard + 30 optional
Drain	ø50 mm, min. flow requirements: 115L/min

Options	IQ4
Soap pump	•
Rinse pump	•
Additional acid dosing pump	•
Additional lubricant dosing pump	•
Condenser	•
Additional water connection	•
Drain pump	•
Acoustic signal	•
Printer	•
COM 2015	•
3. detergent dosing pump	•
3. rinsing dosing pump	•
3. acid dosing pump	•
Eco kit	•
Conductivity sensor	•
Additional water connection	•
Filter guard HEPA	•
COM 2015 XML server connection	•
T-doc server connection	•
Mesh filter	•
Valve for taking water samples	•
Extra computer module needed for options below	•
Stream heating	•
Add detergent pump	•
Condenser	•
Pre filter	•

Models available

KEN IQ4 comes in different editions:

Description	Heating
Single door configuration incl drying module	Electrical
Double doors configuration incl drying module	Electrical
Single door configuration w/o drying module	Electrical
Single door configuration incl drying module	Steam
Double doors configuration incl drying module	Steam
Single door configuration w/o drying module	Steam



Technical machine overview

Front

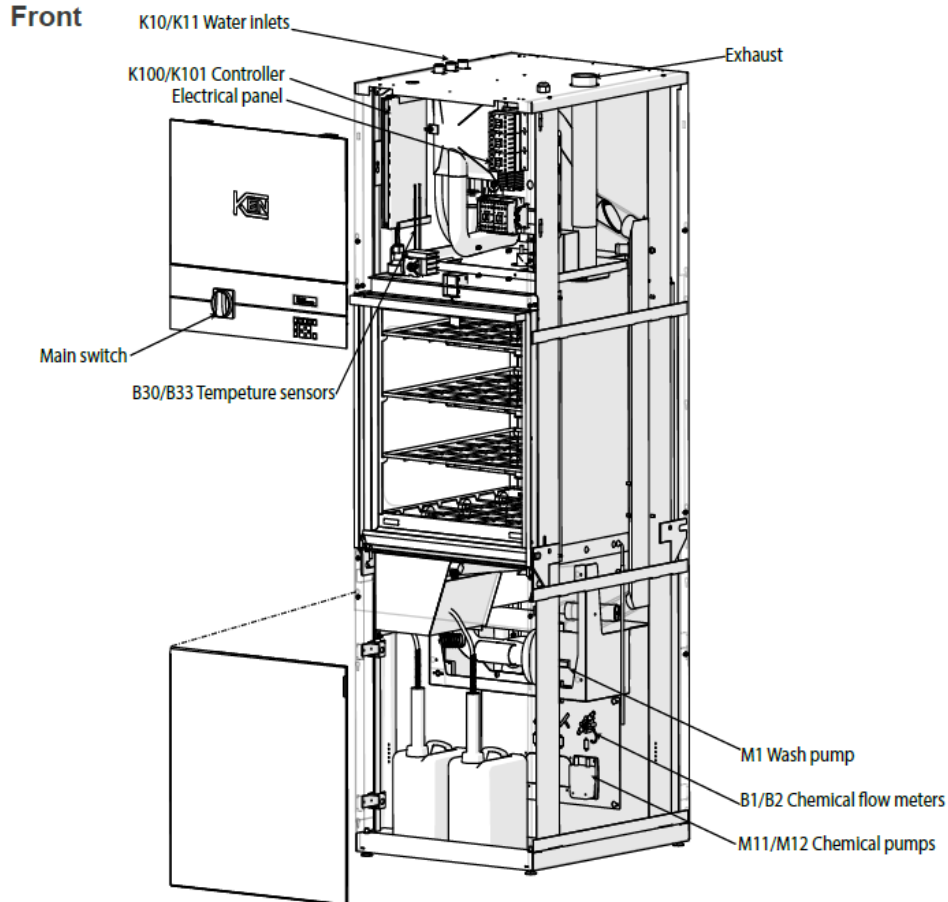

Back

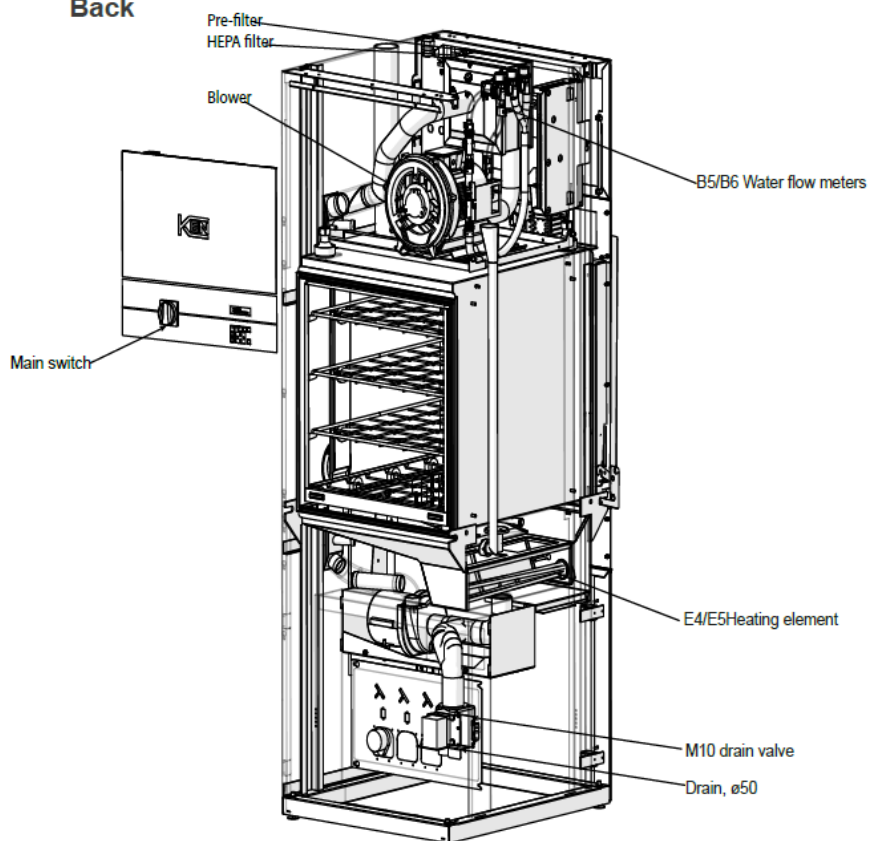

Characteristics of the washing system, water distribution circuits and drying system

High pressure recirculation pump with complete water drainage between each phase of the cycle, avoiding the possibility of entrapment or the accumulation of waste between the different stages during the progression of the washing cycle.

The IQ4 performs an automatic control of the washing pressure to guarantee optimal mechanical force of the water on the instruments during the process. All internal pipes are made of stainless steel having no dead angles to prevent the accumulation of waste water. Including validation ports for thermometric tests in accordance with EN ISO 15883-1,2. Thermo-disinfection is carried out following the guidelines of EN ISO 15883-1, 2 based on a thermodynamic temperature of up to 93 °C and reaching the required A0 value.

The standard configuration includes 2 chemical dosing pumps (detergent + drying agent) fitted with a high precision control system. This high precision dosing system is achieved thanks to the integrated and independent flowmeters connected to each of the dosing pumps. The chemical suction pipes fitted to the dosing system also have individual level sensors that trigger an alarm should the liquid detergent containers reach a low level of product. Further two dosing systems can be added to the standard configuration. Both systems fitted with same control and dosing systems as the standard configuration.

Lower compartment of the unit with dedicated space to store the chemicals used for the process having space for up to 4 x 5 liters cans. The KEN IQ4 washer includes 2 sockets for the connection of cold water and demineralized/reversed osmosis water. Optionally a third outlet can be added for soft (de-ionised) hot water.

As an option, it is possible to include a steam condenser that will collect all the vapors and condensates that the unit exhausts during the drying stage. In addition, our KEN water and heat recovery condensation system recovers the heat energy and water used during the steam condensation process accumulating warm water for the next washing cycle.

High efficiency drying system. Thanks to its high-pressure turbine, the KEN IQ4 optimizes the quality of the drying and is significantly reducing the time required to achieve it. In order to guarantee the quality of the drying air generated by the unit, the KEN IQ4 washer disinfector includes a HEPA filter class H14 having an average life of 3000 - 4000 hours of operation. The IQ4 is optionally able to detect the saturation of the filter as well as blocked airflows, automatically stopping the process in order not to compromise the efficacy and to prevent downtime.

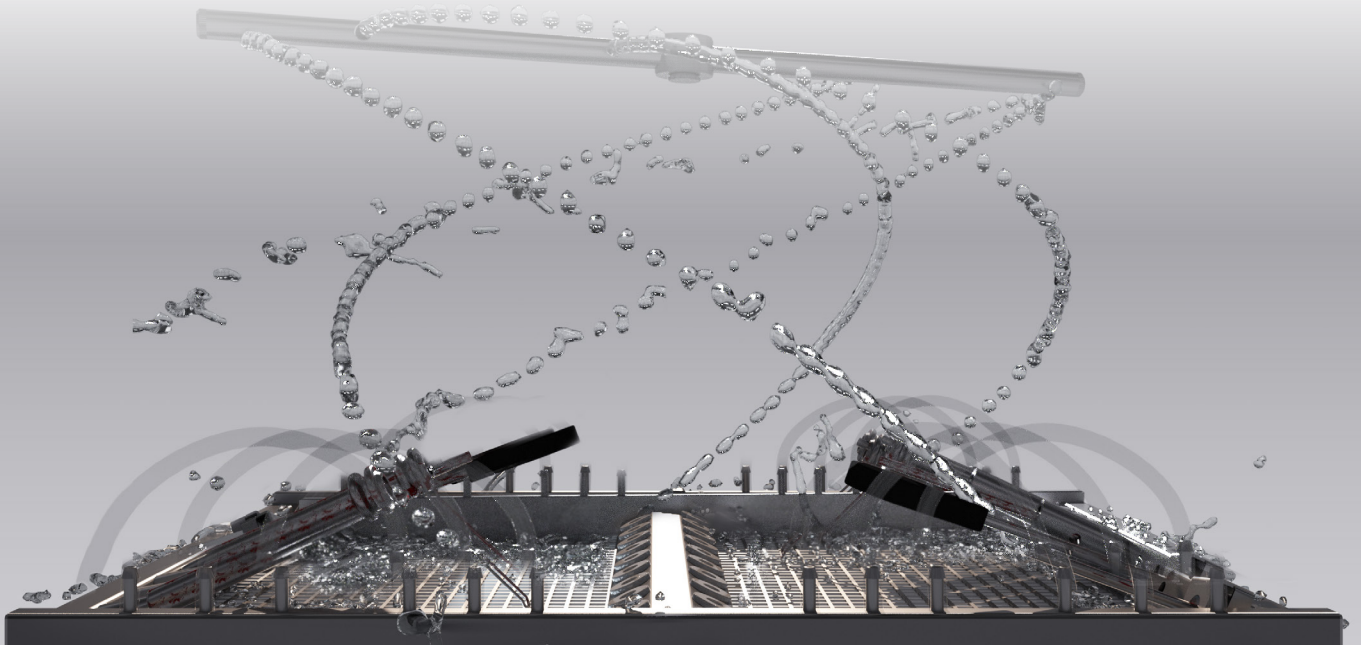

Cycle

The cycle configuration is a sequence of different phases that freely can be configured to meet the function of the process to be performed and to the type of load to be reprocessed; always according to EN ISO 15883.

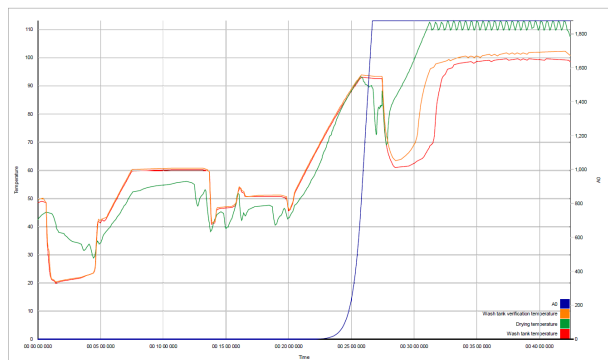

The machine comes with 40 programmable programs and each program may consist of up to 10 phases. Each phase has one of the following phase types:

- Prewash
- Wash
- Rinse
- Disinfection (A0)
- Disinfection (Temperature/Time)
- Drying (Option)

For each phase it is possible to select and adjust parameters. For phases of type prewash, wash or rinse it is possible to select program between different water qualities (if connected), filling method (pressure and level), temperature, duration, 0 to 3 chemistries and conductivities.

For disinfection phase it is possible to select if disinfection should be temperature/time disinfection or an A0 disinfection.

For drying phase it is possible to select a temperature and a duration.

In each phase the following can be individually preset: phase name, water quality, water filling method, filling time, type of chemical (max. 2/phase), dosage time, wash temperature and wash period.

It allows for configuration of cycles and their phases to adapt to the specific needs of items or materials. Cycle phases can as well be fully configured in terms of water inlet, amount of water used, phase temperature, duration of temperature stage, dosing concentration of chemicals, temperature of chemical dosing, recirculation pressure, water recovery or drying temperature and time in case of drying phases.

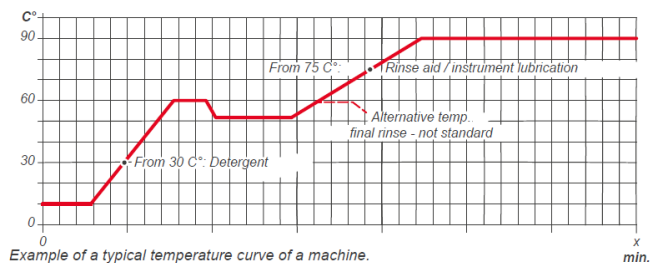

Example of a typical temperature curve of a machine.

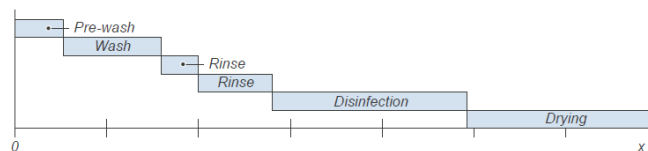

Example of a typical washing and disinfection cycle.

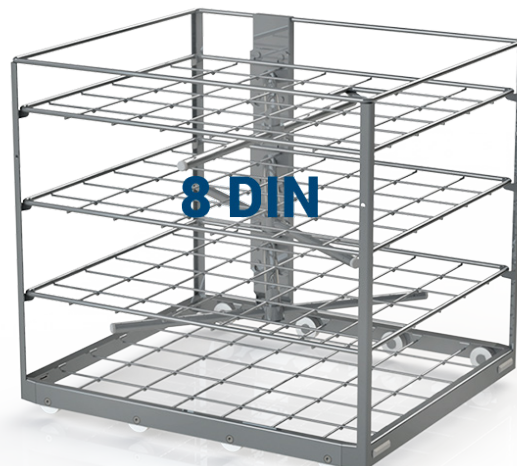



Equipment

The equipment has been manufactured according to high quality standards that ensure reliability and optimum control of its efficiency as well as quick and easy maintenance. The design of the equipment and the choice of all components have been made under the following terms:

- To increase the interval between preventive maintenance inspections.
- Quick and easy access to wear and tear components.

The construction is practical and orderly. Maintenance access of the equipment is carried out only from the front zone. This allows the installation of several fully adjacent units, shoulder by shoulder, without the need for additional lateral access spaces; substantially reducing the space required for these units in the automatic washing area.

Modules and Support

The modules for the base rack are designed for the general or specific need. The idea of using modules for the base rack is to avoid heavy lifting and thus ensure the best possible ergonomic work environment for the user.

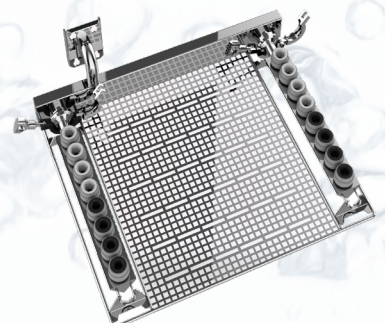
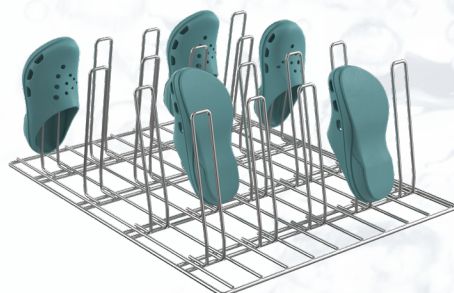
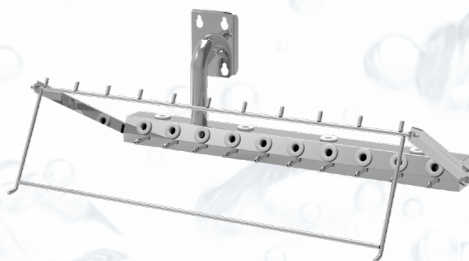
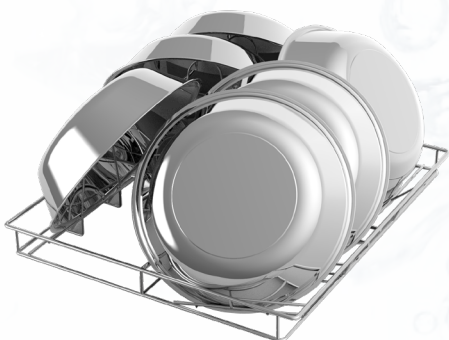

Racks

There is a wide range of equipments depending on the field of application:

- Multilevel rack for instrument baskets
- Flexible racks with washing arms between each level, easily manually removable without the need for tools (allowing us to have 1 to 4 levels of personalized washing in a single rack).



Distributors and Injectors

The distributors are designed to give optimum flexibility. It comes in two types. Either with fixed spikes or with threaded connections for holders. This gives the possibility to optimize the flexibility.

KEN HYGIENE SYSTEMS has always offered a wide range of injectors and nozzles. Injectors and nozzles are now made as plug-in type that makes it very easy for the users to change the set up in the rack.



Loading equipment

Manual trolley for transport



Two-doors

Drawings

Unloading side

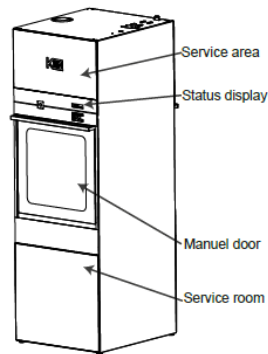

Loading side

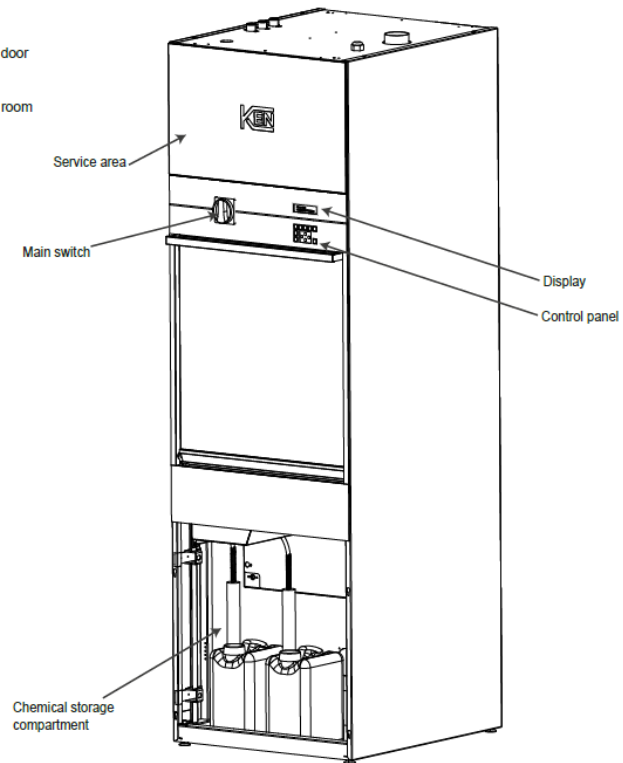

Installation requirements

Bring the machine to a horizontal position using a spirit level and the adjustable machine feet.

Maximum slope of floor: 2°

The machine is designed to operate safely under the following conditions:

1. Indoor use
2. Altitude up to 2000 m
3. Temperatures from 5°C to 40°C
4. Maximum relative humidity: 80% for temperatures up to 31°C decreasing linearly to 50%, relative humidity at 40°C
5. Mains supply voltage fluctuations up to +/-10% of the nominal voltage
6. Overvoltage category II
7. Pollution degree 2

The machine must be connected to cold potable water and soft water (warm is recommended). Demineralized/RO water is optional. Installation of the machine is only permitted in rooms with floor drain.

Installation requirements

Only use approved, reinforced pressure hoses – 3/4" ISO 228/1 for water connections. The necessary backflow protection against reverse suction is integrated in the machine. A shut-off valve must be installed on each water inlet pipe. Water connections not in use must be plugged.

The machine must be connected to a drain in the floor. A 50 mm water trap must be used. The drain connection is placed in the lower cabinet on unloading side. The installation must include an air break to drain.

The exhaust outlet is located on top of the machine. The ventilation system must be made of stainless steel, as there will be condensation in the system. To avoid an increase in pressure or a vacuum in the washing chamber, it is important that the connection from the ventilation system to the machine includes an air gap between the machine and the ventilation system. The air gap must be adjusted to ensure that all heat and moisture is extracted from the outlet of the machine. At the same time the adjustment must prevent vacuum inside the washing chamber, as this will affect the performance of the machine. If a motor damper is fitted in the ventilation system, it is important that it is open before the machine starts the drying phase. Also it is important that the damper is not completely closed, to allow minimum ventilation to remove vapour during washing and disinfecting phases. Signal for ventilation system or damper: See electrical diagram.

The outlet pipe to the free air must have a continuous slope away from the machine to its outlet, unless an automatic drain is fitted at each point where liquid can collect. A maximum of 2 meters is acceptable as a vertical pipe from the machine.

If the machine is heated by means of steam this must be connected with approved pressure hoses – 1/2" ISO 228/1, both steam inlet and condensate. To comply with our requirements for steam quality, it is recommended to install a water discharge (steam trap) immediately before connecting point to the machine's steam valves. At the steam condensate outlet hose, a non-return valve must be installed.

The machine is equipped with an inlet cable and must be connected according to the shown color markings or designations for the single wires and according to the marking label on the machine.

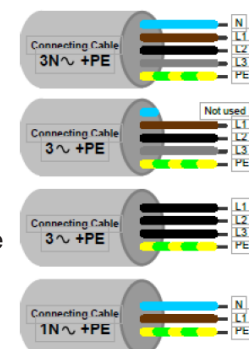

Possible colour markings and designations for connecting cable.

Disclaimer

Do not use this technical data sheet for installation of equipment. Subject to change without notice.



Bøgebjergvej 60, DK-5672 Broby
Tlf. +45 62 63 10 91
Fax +45 62 63 16 07
ken@ken.dk
www.ken.dk

Malones Hospital Services Pty Ltd.
24 Tathra Street West Gosford, 2250, NSW
Phone: +61 (02) 4323 9731
sales@malones.com.au - www.malones.com.au