

# IQ3

## Healthcare

KEN HYGIENE SYSTEMS has developed the smallest version of the IQ series. The IQ3 is designed for washing and disinfection of smaller amounts of equipment in day surgery clinics, dental facilities, private clinics and so on.

The IQ3 is inspired by Danish tradition for design and quality. The elegant Washer Disinfector boosts all the features to meet the latest standards as to high level cleaning and disinfection.



The IQ3 a user friendly Washer Disinfector is easy to operate for the users. The wide selection of racks and supports for instruments and utensils supports the ease of use for the staff in their daily work routines.

In its basic design, the IQ3 is delivered as an under-bench version and it comes in two different sizes to suit every need: One with a build in drying and detergent module and a narrow version without drying for the basic requirements.

For the technical staff the IQ3 supports remote monitoring by a simple network connection without any demands to specific software.

## Key features

- Manual door opening that allows the door to be used as a loading platform
- IQ3 can be installed as under-bench version
- The wide version comes with forced air drying
- Water softener as a standard
- Soft touch panel which makes it easy to operate
- OLED display
- Low chemical usage
- Wide range of racks and modules to meet every need.
- All data are fully exchangeable with track and trace system
- Two different sizes: One with a build-in drying module and one with a condensing drying
- In accordance with EN ISO 15883-1-2-5-6 and EN 61010-2-040
- Remote service access
- Low noise level <58 dB
- Full process validation

## Sustainability statement

KEN HYGIENE SYSTEMS encourages a culture for sustainable development with special attention to the UN Sustainable Development Goals No.'s 3, 8 and 12.



In the development of our machines, we show consideration for the environment and our customers by offering a reduced power and chemical consumption as well as ensuring high productivity, flexible solutions and an optimization of the workflow.



## Standards

KEN HYGIENE SYSTEMS IQ3 complies with the following standards:

- EN ISO 15883-1-2-5-6: Washer disinfectors
- EN ISO 13485: Development and production of washer disinfectors.
- EN 1717 Protection of potable water
- EN 61010-2-040: Particular requirements for sterilizers and washer-disinfectors for medical purposes.
- EN IEC 60601: (EMC)
- Council Directive 93/42/EEC with supplement 2007 /47 /EC (Directive for Medical Device Class II b products).

Made according to Annex IX of the European Medical Device Directive 93/42/EEC and manufactured in accordance with Annex I to that directive.

Technical specification	IQ3
External dimensions	H: 840 x W: 600 x D: 630 mm
External dimensions with drying module	H: 840 x W: 900 x D: 630 mm
Weight excl./incl. packaging	105 / 112 kg
Weight excl./incl. packaging w. drying module	135 / 142 kg
Operative volume, wash chamber	150 L
Total volume, wash chamber	170 L
Capacity DIN-baskets 480x250x50	4 x 2
Cycle time, standard	40-60 min without drying 60-80 min with drying
Condenser	Standard
Water connections	2 x 3/4 (2x optional)
Water connections with drying module	1 x 3/4 (2x optional)
Cold water	200-800kPa, ≥ 10 L/min, 5-30°, 0-30° dH
Hot water	200-800kPa, ≥ 10 L/min, 30-70°, 0-3° dH
Deminerlized / RO water	200-800kPa, ≥ 10 L/min, 5-70° - option
Washing / Drying	<58 dB (A) / <54 dB (A)
Water consumption per phase	Approx. 8-14 L (depending on load)
Power supply options	3x230-415V AC + N + PE, 50/60 Hz 7 kW
Programs available	10 standard + 30 optional
Drain pump	ø32 mm

Options	IQ3	IQ3 Side cabinet
2. water connection	•	•
3. water connection	•	•
2. dosing pump	•	•
3. dosing pump	•	•
Flowmeter for one dosing pump	•	•
Flowmeter for two dosing pumps	•	•
Flowmeter for three dosing pumps	•	•
Direct water connection to chamber	•	•
Drain cooling	•	•
Power 9kw	•	•
XML-connect	•	•
Conductivity sensor	•	•
Stand basic stainless steel 60cm	•	
Stand basic stainless steel 90cm		•
Stand and storage cabinet for chemicals 60cm	•	
Stand and storage cabinet for chemicals 90cm		•
Printer	•	•
Acoustic signal	•	•



## Documentation

A machine delivery includes one set of the following documentation:

- User manual
- Technical manual
- Standard spare part list
- Quality inspection certificate
- Temperature test diagram
- Declaration of conformity

## Control units

Intuitive and operator friendly thanks to our KEN Com 2015 user interface, common for all KEN machines. The KEN IQ3 Washer Disinfector performs a comprehensive control of all parameters and processes performed. Its dual independent microprocessor ensures the correct cleaning, disinfection and drying of materials cycle after cycle.

The IQ3 communicate with the operator through the integrated OLED display. This displays the cycle parameters, monitors the operation configuration, provides information on the progress of the cycle; Shows date, time, wash cycle, phase, error messages, end of cycle and all information necessary to the user or the technician. The microprocessor has a storage capacity for up to 40 different programs that have an open and unlimited configuration structure and allows a high level of personalized cycles in order to meet the needs that a healthcare facility may require.

The KEN IQ family can all be network connected through the integrated Ethernet socket. This allows for direct communication with the unit through any web browser without the use of any specific software. Connecting to the batch data of the unit will allow the user to print out or digitally store individual program reports. These standard options can save the use of a printer and the use of paper. Connecting the unit to the network also allows if access is granted to KEN service specialists to connect to the machine and assist in case of breakdown or to offer remote assistance to users.

# Cycle

The cycle configuration is a sequence of different phases that freely can be configured to meet the function of the process to be performed and to the type of load to be reprocessed; always according to EN ISO 15883.

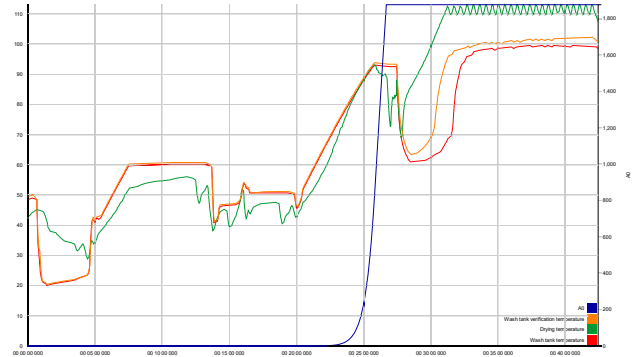

The machine comes with 40 programmable programs and each program may consist of up to 10 phases. Each phase has one of the following phase types:

- Prewash
- Wash
- Rinse
- Disinfection (A0)
- Disinfection (Temperature/Time)
- Drying (Option)

For each phase it is possible to select and adjust parameters. For phases of type prewash, wash or rinse, it is possible to select different water qualities (if connected), filling method (pressure or level), temperature, duration, to 3 chemistries and conductivity level (option).

For disinfection phase it is possible to select if disinfection should be temperature/ time disinfection or an A0 disinfection. For drying phase it is possible to select a temperature and a duration.

In each phase the following can be individually preset: phase name, water quality, water filling method, filling time, type of chemical (up to 2/phase), dosage time, wash temperature and wash duration.

It allows for configuration of cycles and their phases to adapt to the specific needs of items or materials. Cycle phases can as well be fully configured in terms of water inlet, amount of water used, phase temperature, duration of temperature stage, dosing concentration of chemicals, temperature of chemical dosing, recirculation pressure or drying temperature and time in case of drying phases.

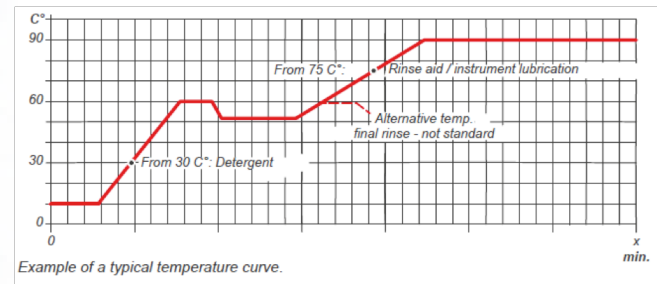

Example of a typical temperature curve.

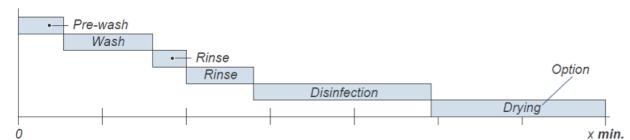

Example of a typical washing and disinfection cycle.

## Equipment

The loading systems for KEN IQ3 is designed in stainless steel. It is normally configured for the standard rack system "Flexi Rack", but shelves are also available. It is possible to get racks up to 4 levels.

If you chose the rack system, you need to have minimum 1 rack to use in the machine. Otherwise if you chose the shelf system you can use the machine with one shelf but two is the better choice.

The shelves for IQ3 are designed to wash tall items in 1 level or smaller and medium sized items in 2 levels.

The Flexi System makes it easy to equip the machine with the right accessories for any kind of equipment.

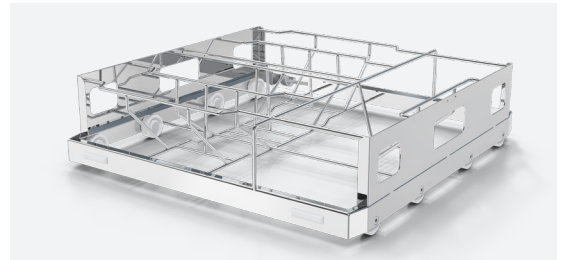
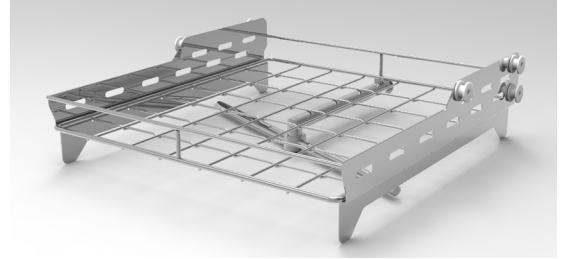

### IQ3 Rack up to 4 levels



## Drawings

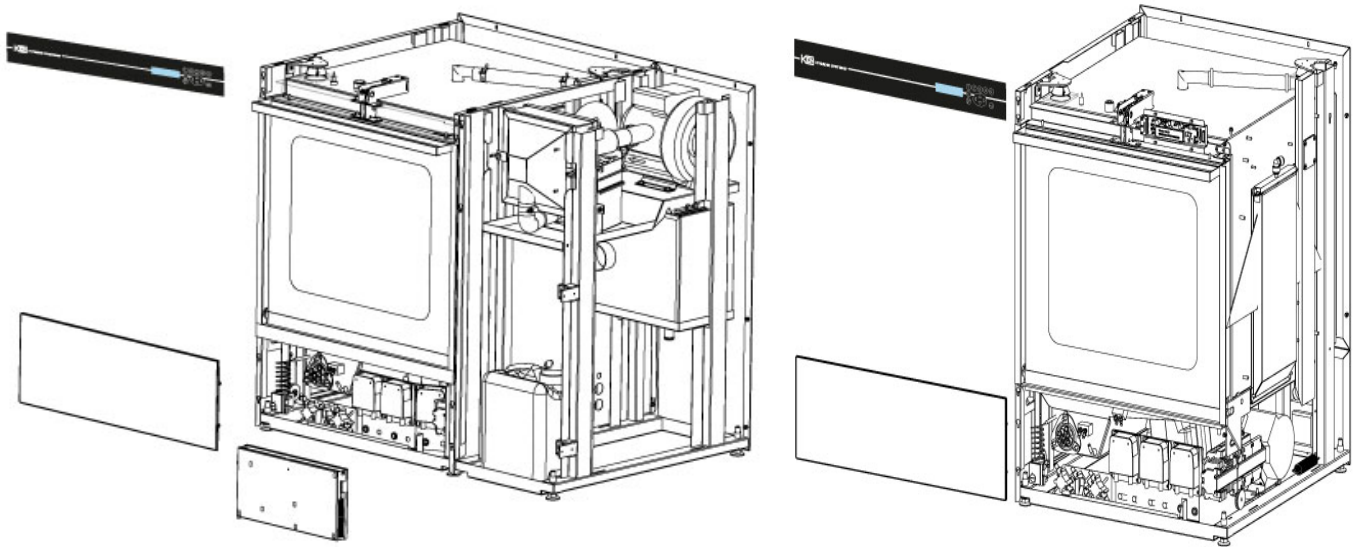

## Installation requirements

Bring the machine to a horizontal position using a spirit level and the adjustable machine feet. Increase of the height can be up to 35 mm.

- Maximum slope of floor: 2°
- Height from floor to loading/unloading: min. 273 mm.

The machine is designed to operate safely under the following conditions:

1. Indoor use
2. Altitude up to 2000 m
3. Temperatures from 5°C to 40°C
4. Maximum relative humidity: 80% for temperatures up to 31°C decreasing linearly to 50%, relative humidity at 40°C
5. Mains supply voltage fluctuations up to +/- 10% of the nominal voltage
6. Overvoltage category II
7. Pollution degree 2



## Installation requirements

The machine must be connected to cold water. Soft water or demineralized/RO water is optional.

Only use approved, reinforced pressure hoses – 3/4 ISO 228/1 for water connections. The necessary back-flow protection against reverse suction is integrated in the machine. A shut-off valve must be installed on each water inlet pipe.

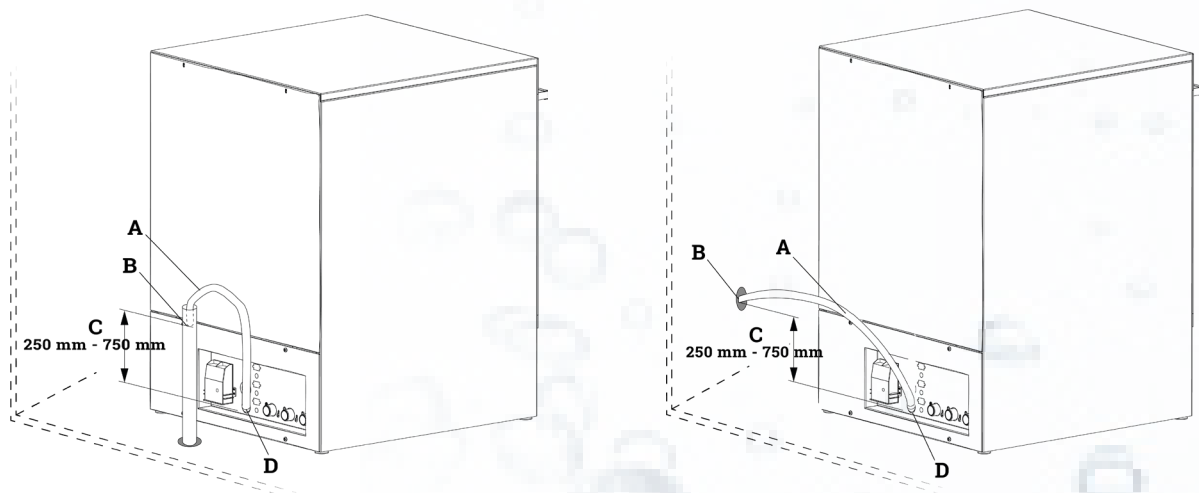

The drain hose (A) is fitted at the rear of the cabinet. To prevent the water to drain out during the wash cycles it is important to position the drain outlet (B) at a specific height. The drain hose from the machine must end at a height (C) between 250 mm and 750 mm from the drain (D) of the machine. The installation must include an air break to the drain.

The machine is equipped with an inlet cable and must be connected according to the below shown color markings or designations for the single wires and according to the marking label on the machine

## Disclaimer

Do not use this technical data sheet for installation of equipment. Subject to change without notice.



Bøgebjergvej 60, DK-5672 Broby  
Tlf. +45 62 63 10 91  
Fax +45 62 63 16 07  
ken@ken.dk  
www.ken.dk

Malone Hospital Services Pty Ltd  
24 Tathra Street West Gosford, 2250, NSW  
Phone: +61 (02) 4323 9731  
sales@malones.com.au - www.malones.com.au